



IP 54
Control Panel



Digital
Monitor display



Days meter
for lamp life control



Acoustic alarm
for lamp
replacement

BIG F PRO

Atlas **BIG F PRO** is an easy to install two stage filtration system with UV treatment, for the removal of sediment and for water purification by means of UV-C radiation. **UV-C treatment** is a physical disinfection treatment for the inactivation of microorganisms in water.

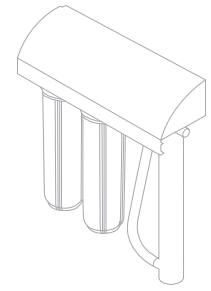
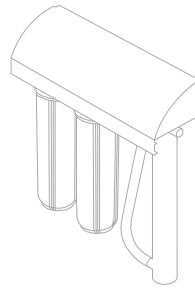
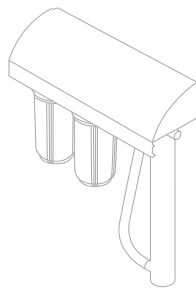

Filtration-stage 1	20 µm	20 µm	20 µm
Filtration-stage 2	5 µm	5 µm	5 µm
Cartridges	TS 10" BIG 20 µm CARBON BLOCK 10" BIG 5 µm	TS 20" BIG 20 µm CARBON BLOCK 20" BIG 5 µm	TS 20" BIG 20 µm CARBON BLOCK 20" BIG 5 µm
Inlet/outlet size	1"	1"	1"
Shipping weight	20 Kg	22 Kg	22 Kg
Max working temperature	45 °C	45 °C	45 °C
Max working pressure	8,3 bar	8,3 bar	8,3 bar
Flowrate	54 lpm (40mJ/cm ²)	70 lpm (30mJ/cm ²)	95 lpm (30mJ/cm ²)
Total consumption	61 W	61 W	73 W
Metal frame	Varnished galvanized steel with key lock	Varnished galvanized steel with key lock	Varnished galvanized steel with key lock

UV LAMP GENERAL INFORMATION

UVC transmittance	95% - 1 cm	95% - 1 cm	95% - 1 cm
-------------------	------------	------------	------------

UV REACTOR

Material	Stainless Steel 304	Stainless Steel 304	Stainless Steel 304
Connections	Thread 1" M	Thread 1" M	Thread 1" M
Max working pressure	8,3 bar	8,3 bar	8,3 bar
Protection class	IP 54	IP 54	IP 54

UV LAMP

Lifespan	9000 hrs	9000 hrs	9000 hrs
Lamp power	56 W	56 W	67 W
Type	HO low pressure	HO low pressure	HO low pressure

CONTROL PANEL

Material	Thermoplastic	Dimension	218x113x60 mm	Protection class	IP 64	Power supply	110-240 V - 50/60 Hz
Power cable	2 mt	Feed plug	AUS Type I	Monitor display	Digital	Days meter	For total system life
Resettable days meter	For lamp life control	Audio alarm	With silence options				

DP BIG DUO filter housing

mod. 156

stage1

stage2

TS 10" BIG 20 µm



CARBON BLOCK 10" BIG 5 µm

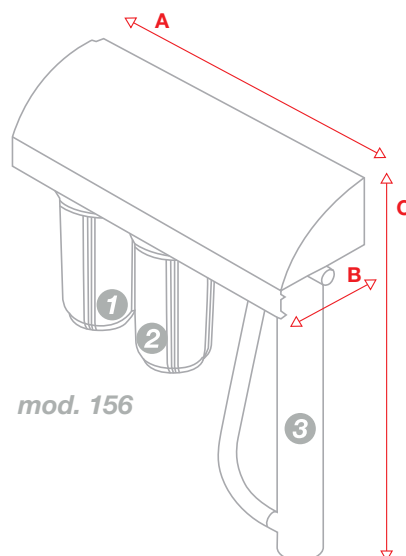
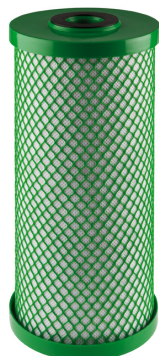

A = 722 mm
B = 205 mm
C = 790 mm

mod. 156

mod. 256 / 267

TS 20" BIG 20 µm



CARBON BLOCK 20" BIG 5 µm

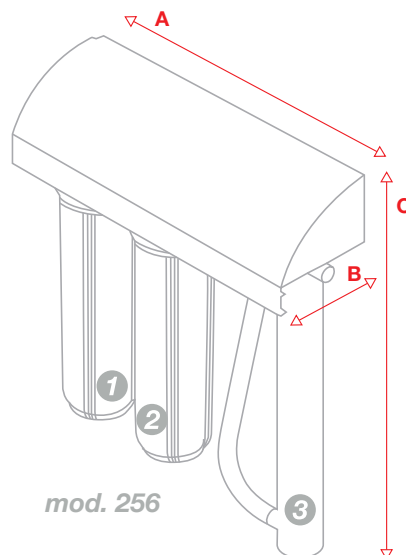
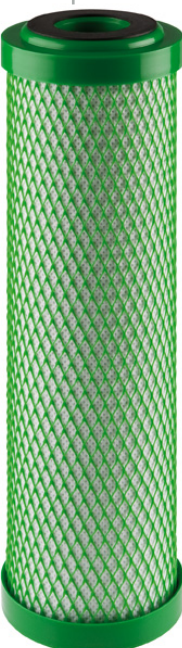

A = 722 mm
B = 205 mm
C = 806 mm

mod. 256

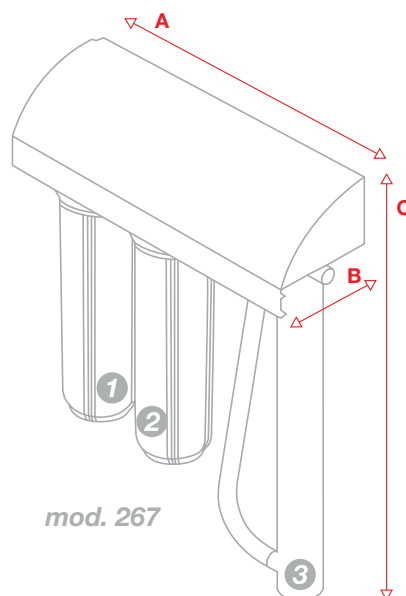

A = 722 mm
B = 205 mm
C = 870 mm

mod. 267

UV lamp stage3

mod. 156/256

56 W

mod. 267

67 W

We value
what really
matters.
Water



IT'S MADE IN ITALY